

Programmable transmitter 6746 with frequency output

- Thermocouples B,C,D,E,G,J,K,L,N,R,S,T
- RTD sensors Pt100, Pt500, Pt1000 and Ni100, Ni1000
- Process inputs: 0..20mA, 4..20 mA, -20 .. +20 mA
0..5 V, 0..10 V, -10 .. +10 V
- mV-range -100 .. +100 mV
- IR-thermopile sensors
- Configuration by PC or with a hand held programmer
- Galvanic isolation between input, output and power supply
- Output 0..2.5 kHz
- Power supply 24VDC

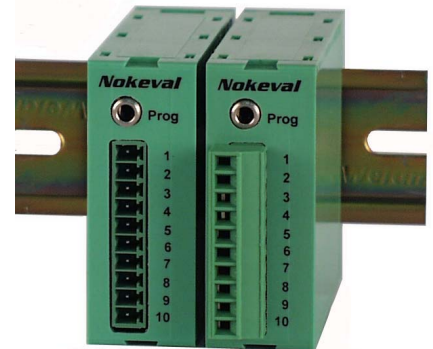

Transmitter 6746 is exceptionally versatile accepting almost all the most common temperature sensor inputs and process inputs as well. The transmitter has frequency output 0-2.5 kHz. The use of counters provides an economical means of transmitting measuring data to instruments where an analog input is not possible or when a more cost-effective solution is sought after.

The programming of the transmitter is simple by the MekuWin configuration software or with the hand held programmer 6790, which is especially practical in field conditions. Emissivity can be set according to the measuring target.

A high measuring accuracy is reached by a 16-bit analog converter, the linearity of which is < 0,005%. Conversion accuracy of the output is 0,05% without linearization error of the sensor. Inputs and outputs are galvanically isolated from each other and the power supply.

The transmitter is an excellent choice when one wants to reduce the number of instruments in storage by replacing several models with one transmitter.

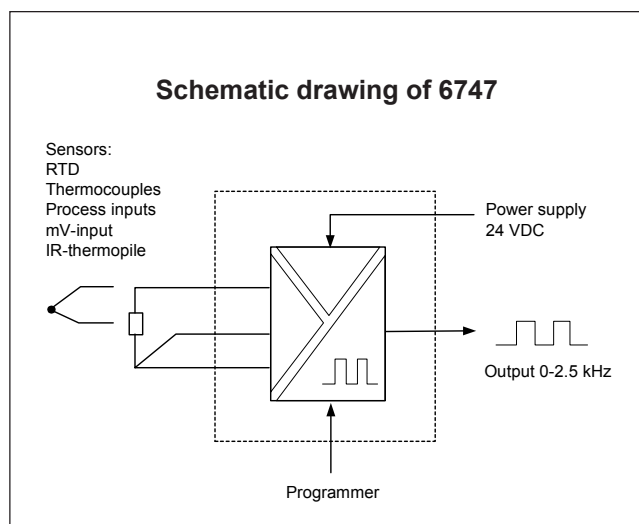

Technical specification:

Thermocouples:

Sensor	Range	Linearity
E	-100... 900°C	< 0.3°C -50... 900°C
J	-150... 900°C	< 0.3°C -50... 900°C
K	-150... 1350°C	< 0.4°C -40... 1300°C
L	-100... 900°C	< 0.4°C -50... 900°C
T	-150... 400°C	< 0.3°C -150... 400°C
N	0... 1300°C	< 0.4°C 0... 1300°C
R	0... 1700°C	< 0.4°C 400... 1700°C (<1°C < 300 °C)
S	0... 1700°C	< 0.4°C 300... 1700°C (<1°C < 300 °C)
C (W5)	0... 2200°C	< 0.4°C 400... 2200°C (<0.4°C < 400 °C)
D (W3)	0... 2200°C	< 0.4°C 500... 2200°C (<1°C < 500 °C)
B	400... 1700°C	< 0.5°C 400... 1700°C
G (W)	1000... 2200°C	< 0.5°C 1000... 1700°C (<3 °C >1700 °C)
Range selection	freely selectable	
Calibration accuracy	< 0.1 % of max. span	
Cold junction compensation	< 0.05 °C / °C	
Sensor wire influence	< 10 kohm, negligible	

RTD's:

Range	Pt100, Pt500, Pt1000, Ni100 -200...+700 °C (Pt100, Pt500) -200...+300 °C (Pt1000) -60...+175 °C (Ni100)
Sensor connections	3-, 4-wire connection
Max. sensor wire resistance	<30 ohm /wire
Sensor current	0.3 mA typical
Accuracy	0.1 % of reading (°C) +0.1 °C
Calibration accuracy	±0.1 °C (0 °C)
Linearity	< 0.1 °C (-200...+700 °C)
Sensor error correction	freely offset and span corrections
Other resistance inputs	0-1000 ohm, potentiometer 50-500 ohm

mV-inputs:

Accuracy	-100...+100 mV 0.02 % of span
Linearity	0.01 % of span
Input impedance	>10 Mohm

Process inputs:

Input impedance	0..20 mA, 4..20 mA, -20...+20 mA, 0.5, 0..10 V, -10...+10V
Accuracy	Current: 5 ohm and voltage: 1 Mohm 0.02 % of span
Linearity	0.01 % of span

IR-sensors:
 Range 140F-K (60°C) -40...+350°C (linearized range)
 Range 440F-K (220°C) -30...+600°C (linearized range)
 Emissivity correction selectable by PC or programmer

Output:
 Output up to max. 2.5 kHz, Galvanically isolated
 Output scaling freely scaleable on the whole range,
 reverse function selectable
 Sensor break programmable 0 or 2,5 kHz
 Voltage level 0/15V
 Max. load max. 20 mA (1 kohm)
 Configuration by MekuWin software in PC or hand held programmer 6790

General:
 Power supply 24 VDC, ±15 %
 Power consumption max. 40 mA
 Temperature effects <0.005 %/°C of input range
 Galvanic isolation input/output 1000 VDC/ 1 min.
 Measuring rate 4 samples/s.
 AD-converter 16 bit
 Output DAC 12 bit
 Operating temperature 0..60 °C
 Ambient storage -20...+70 °C
 Humidity (non-condensing) 0..95 %RH
 Weight 80 g
 Connection 1.5 mm², AWG 16
 Protection IP20

How to order:

The transmitter can be freely programmed by configuration devices. The transmitters can also be delivered with customer settings according to the ordering instructions below.

Code 6746 - Pt100 - 0/600

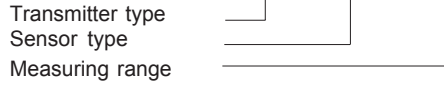

Example 6746-Pt100-600, sensor Pt100, measuring range 0..600 °C, output 0..2,5 kHz

Optional:
 Configuration software MekuWin for a PC
 Hand held programmer 6790

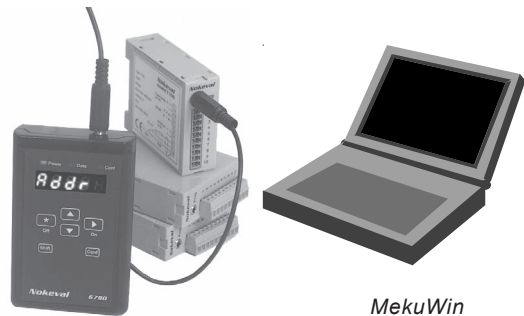

Programmer 6790

MekuWin software

Connections

Input connections

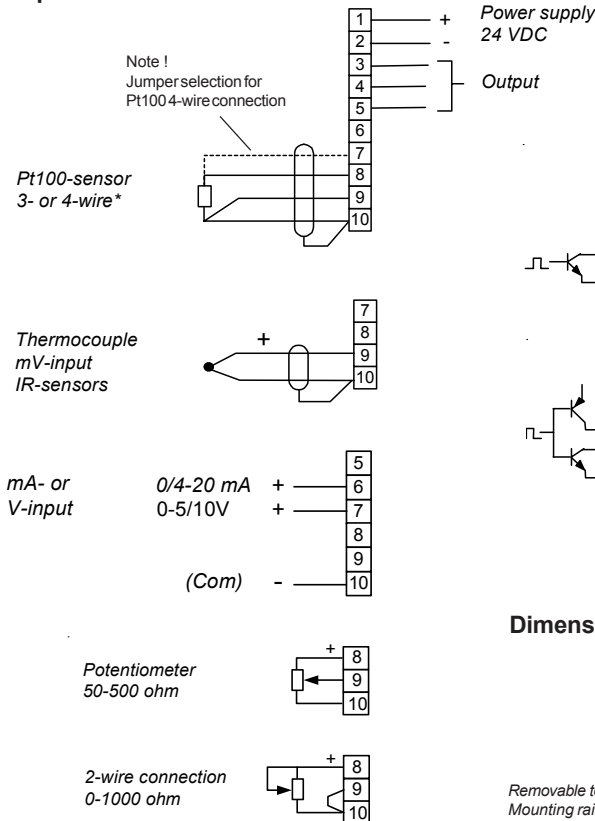

Output connections

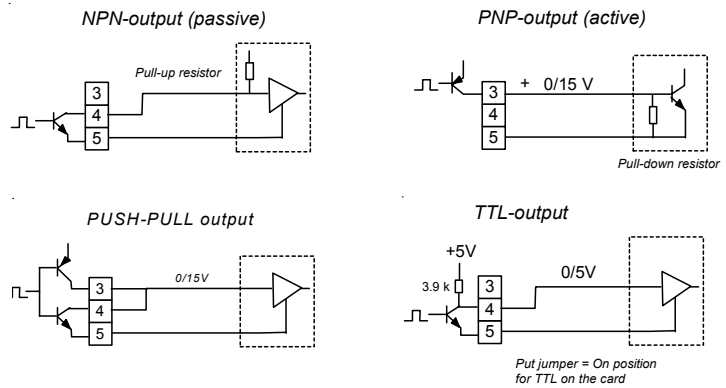

Dimensions

